

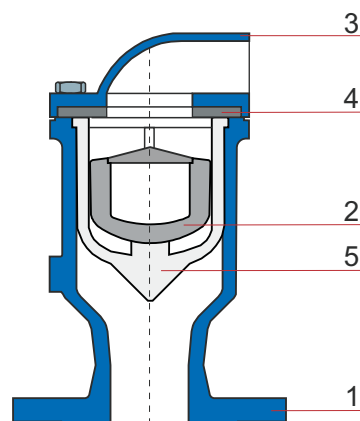

Les ventouses double effet évacuent l'air durant le remplissage ou la vidange d'une conduite et facilitent ainsi l'écoulement de l'eau.

No	DESCRIPTION	MATERIEL
1	CORPS	GS 40 EN1563
2	FLOTTEUR	Plastique ABS
3	COUVERCLE	GS 40 EN 1563
4	SIEGE	EPDM
5	CAGE	Plastique ABS

DESCRIPTION

Brides

Dimensions

Pression de service

Pression min.

Revêtement

Testing

NORMES

EN 1563 / EN 1092-2

DN 40 - DN 300

PN 10-16-25-40-64-100

0,2 Bar

Poudre epoxy 250 microns DIN 30677

EN 1074.04

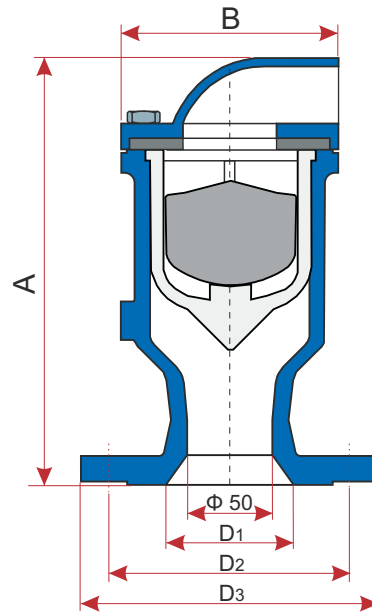
DIMENSIONS PN 10 - PN 16

TYPE	DN mm	A	B	C	L	D1	D2	D3	Kg
400	40	260	140	84	110	40	110	150	8,0
	50	260	140	84	110	50	125	165	8,5
	60	260	140	84	110	65	135	185	11,5
	60/65	260	140	84	110	65	145	185	11,5
	80	260	140	84	110	80	160	200	12,5
100	260	140	84	110	100	180	220	13,3	

DIMENSIONS PN 25

TYPE	DN mm	A	B	C	L	D1	D2	D3	Kg
400	40	260	140	84	110	40	110	150	8,0
	50	260	140	84	110	50	125	165	8,5
	60	260	140	84	110	65	135	185	11,5
	65	260	140	84	110	65	145	185	11,5
	80	260	140	84	110	80	160	200	12,5
	100	260	140	84	110	100	190	235	13,3

DIMENSIONS PN 40

TYPE	DN mm	A	B	C	L	D1	D2	D3	Kg
400	40	260	140	84	110	40	110	150	8,0
	50	260	140	84	110	50	125	165	8,5
	60	260	140	84	110	65	135	185	11,5
	65	260	140	84	110	65	145	185	11,5
	80	260	140	84	110	80	160	200	12,5
	100	260	140	84	110	100	190	235	13,3

DIMENSIONS PN 64

TYPE	DN mm	A	B	C	L	D1	D2	D3	Kg
400	40	260	140	84	110	40	125	170	16,0
	50	260	140	84	110	50	135	180	17,0
	65	260	140	84	110	65	160	205	18,0
	80	260	140	84	110	80	170	215	19,0
	100	260	140	84	110	100	200	250	21,5

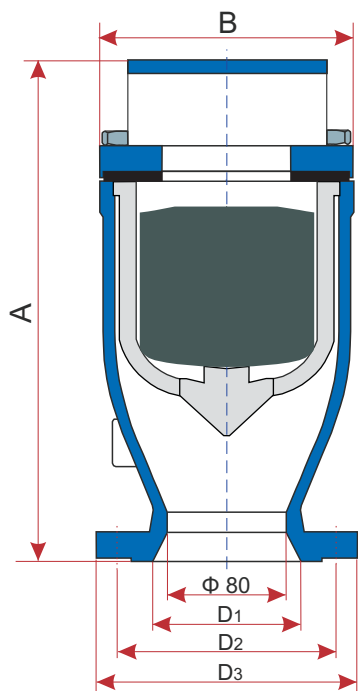
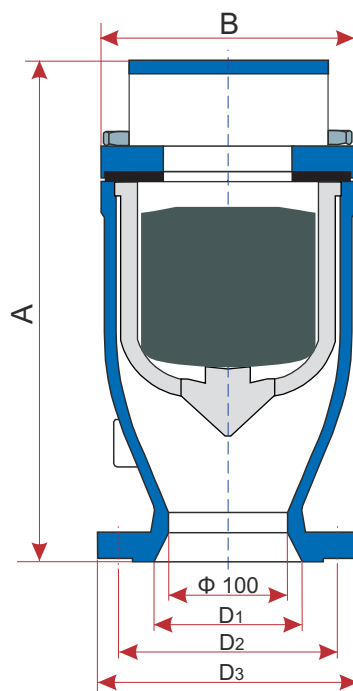
TYPE 600

TYPE 900
DIMENSIONS PN 10 (PN 16)

TYPE	DN mm	A	B	C	L	D ₁	D ₂	D ₃	Kg
600	80	340	195	112	110	80	160	200	25,0
	100	340	195	112	110	100	180	220	25,5
900	100	390	215	122	110	100	180	220	25,5
	125	390	215	122	110	125	210	250	30,0
	150	390	215	122	110	150	240	285	35,0
	200	390	215	122	110	200	295	340	37,0
	250	390	215	122	110	250	350(355)	395(405)	48,0
	300	396	215	122	110	300	400(410)	445(460)	55,0

DIMENSIONS PN 25

TYPE	DN mm	A	B	C	L	D ₁	D ₂	D ₃	Kg
600	80	340	195	112	110	80	160	200	24,0
	100	340	195	112	110	100	190	235	27,0
900	100	390	215	122	110	100	190	235	28,0
	125	390	215	122	110	125	220	270	31,0
	150	390	215	122	110	150	250	300	35,0
	200	390	215	122	110	200	310	360	36,0
	250	390	215	122	110	250	370	425	48,0
	300	396	215	122	110	300	430	485	55,0

DIMENSIONS PN 40

TYPE	DN mm	A	B	C	L	D ₁	D ₂	D ₃	Kg
600	80	340	195	112	110	80	160	200	24,0
	100	340	195	112	110	100	190	235	27,0
900	100	390	215	122	110	100	190	235	28,0
	125	390	215	122	110	125	220	270	31,0
	150	390	215	122	110	150	250	300	35,0
	200	390	215	122	110	200	320	375	42,0
	250	390	215	122	110	250	385	450	61,0
	300	396	215	122	110	300	450	515	71,0

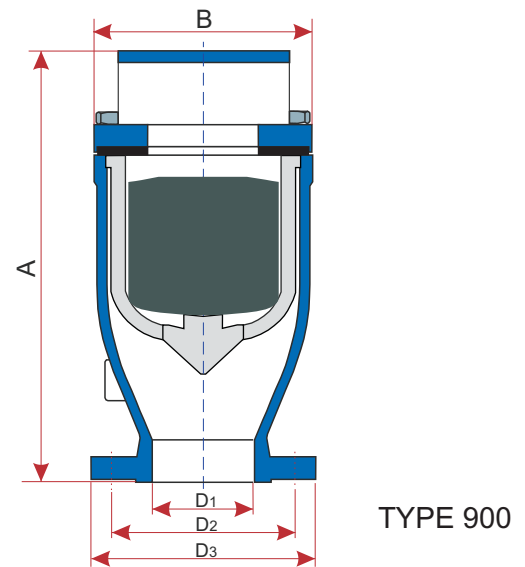
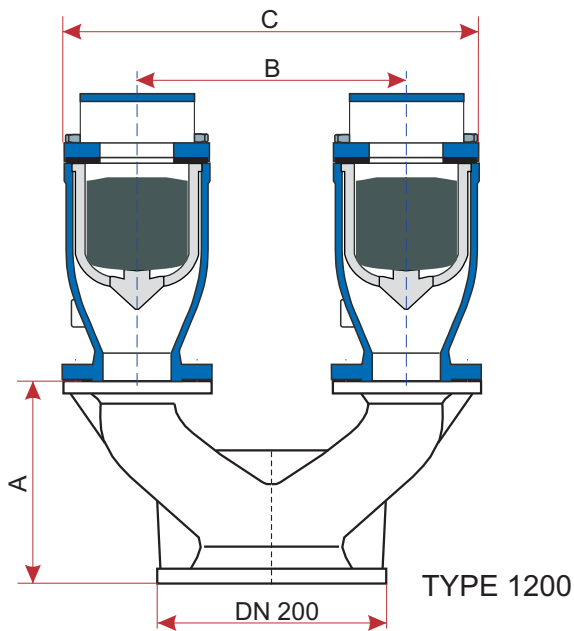

Les ventuses double effet évacuent l'air durant le remplissage ou la vidange d'une conduite et facilitent ainsi l'écoulement de l'eau.

DIMENSIONS PN 10 (PN 16)

TYPE	DN mm	A	B	C	D1	D2	D3	Kg
900	100	390	215		100	180	220	25,5
	125	390	215		125	210	250	30,0
	150	390	215		150	240	285	35,0
	200	390	215		200	295	340	37,0
	250	390	215		250	350(355)	395(405)	48,0
	300	396	215		300	400(410)	445(460)	55,0
1200	200	300	400	615	100	180	220	95,0

DESCRIPTION

NORMES

Brides	EN 1563 / EN 1092-2
Dimensions	DN 200
Pression de service	PN 10-16-25-40
Pression min.	0,2 Bar
Revêtement	Powder epoxy 250 microns DIN 30677
Testing	EN 1074.04

TYPE 400 - 600 - 900 - 1200 GRAND ORIFICE

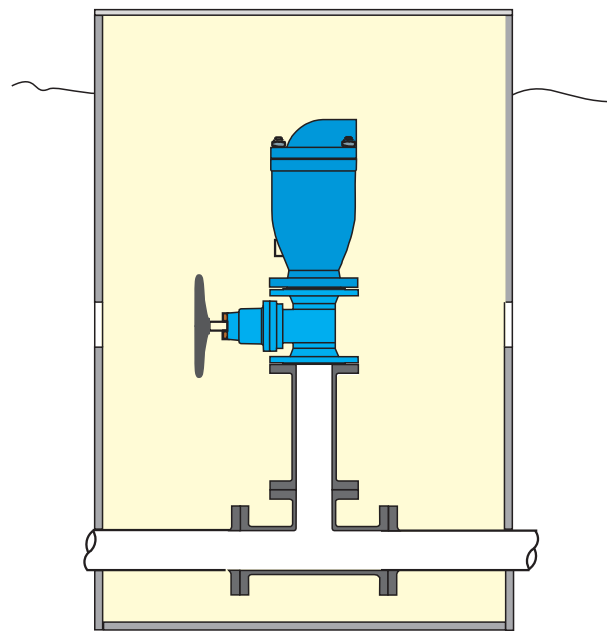
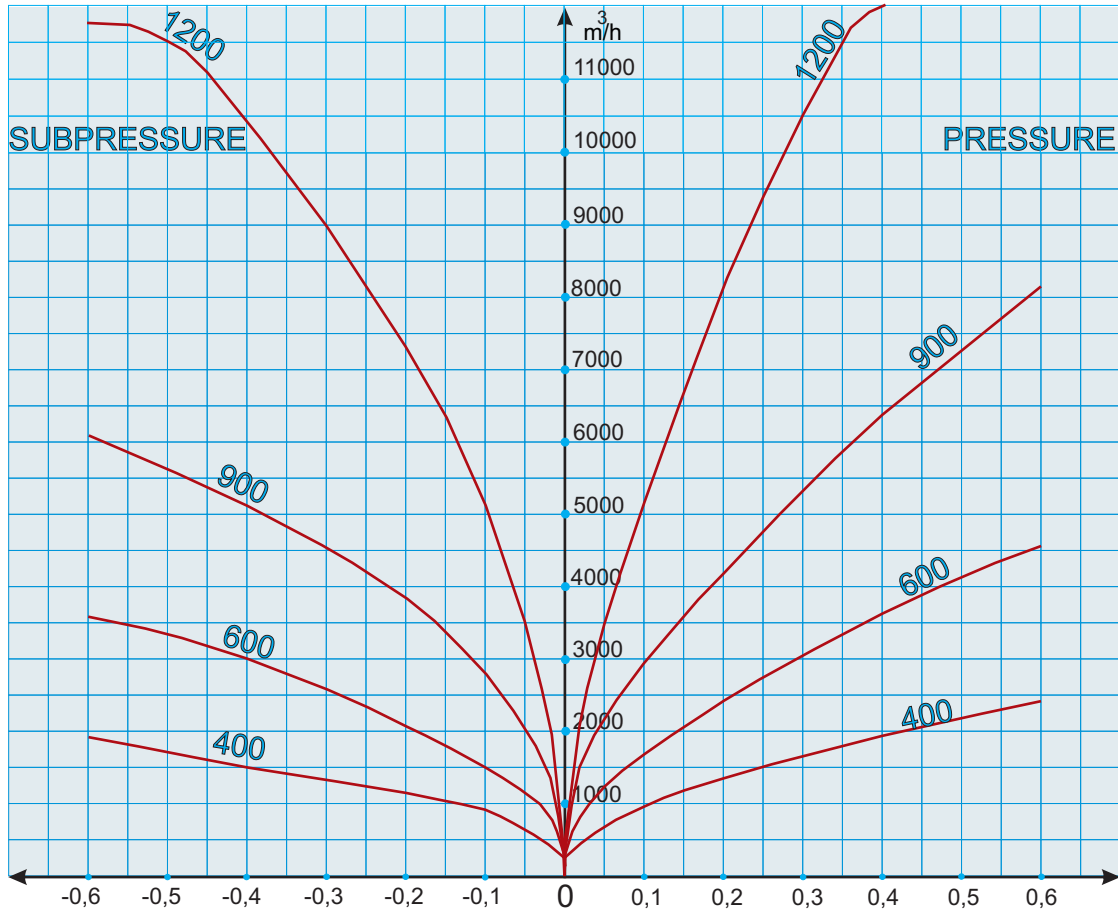

MONTAGE